

# Chiller Plant Design

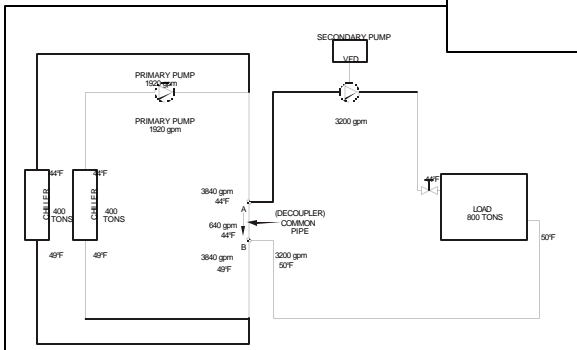
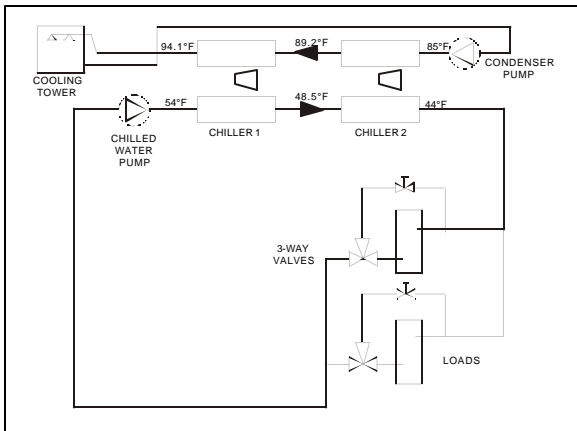

# Table of Contents

Introduction.....	3
Typical Piping Design Concepts .....	3
Single Chiller Loop.....	3
Parallel Chillers.....	9
Water-Side Free Cooling.....	18
Hybrid Plants.....	19
Variable Flow Design.....	20

Document Number:     AG 31-003  
Revision:               February 2001

---

## NOTICE

The information contained within this document represents the opinions and suggestions of McQuay International. Equipment, and the application of the equipment and system suggestions are offered by McQuay International as suggestions only, and McQuay International does not assume responsibility for the performance of any system as a result of these suggestions. The system engineer is responsible for system design and performance.

---

"McQuay " is a registered trademark of McQuay International  
©2001 McQuay International

"Illustrations, information, and data cover McQuay International products at the time of publication and we reserve the right to make changes in design and construction at anytime without notice"

# Introduction

Using chilled water to cool a building or process is efficient and flexible. A two inch schedule 40 pipe of chilled water can supply as much comfort cooling as 42" diameter round air duct. The use of chillers allows the design engineer to produce chilled water in a central building location or even on the roof and distribute the water economically and without the use of large duct shafts. Chilled water also provides accurate temperature control that is especially useful for VAV applications.

The purpose of this manual is discuss various piping and control strategies commonly used with chilled water systems including variable flow pumping systems.

## Typical Piping Design Concepts

The most common piping strategies for HVAC systems are:

- single chiller loop
- parallel chillers
- series chillers
- primary/secondary (or decoupled) systems.

### Single Chiller Loop

Figure 1 shows a basic chiller loop with a water-cooled chiller. The system consists of a chiller, cooling tower, cooling load, chilled water and condensing water pumps and piping.

**Figure 1, Single Chiller Loop**

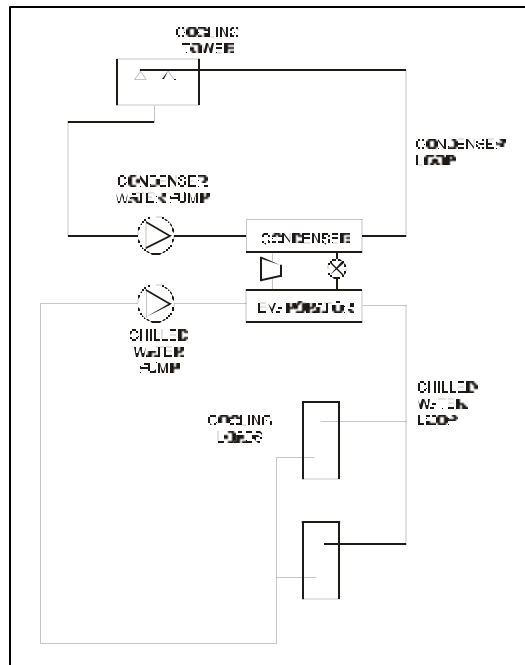

#### Chiller

The chiller can be either air- or water-cooled. The compressor types typically are reciprocating, scroll, screw or centrifugal. The evaporator can be remote from the condensing section on air-cooled units. This has the advantage of keeping the chilled water loop inside the building envelope when using an outdoor chiller.

The chilled water flows through the evaporator of the chiller. The evaporator is a heat exchanger where the chilled water gives up its sensible heat (the water temperature drops) and transfers the heat to the refrigerant as latent energy (the refrigerant evaporates or boils).

For air conditioning applications, the common design conditions are 44°F supply water temperature and 2.4 gpm/ton. The temperature change in the fluid for either the condenser or the evaporator can be described using the following formula ;

$$Q = W \times C \times \Delta T \quad (1)$$

Where

Q = Quantity of heat exchanged (btu/hr or kW)

W= flow rate of fluid (USgpm or l/s)

C= specific heat of fluid (btu/lb °F or kJ/(kg °K))

ΔT= temperature change of fluid (°F or °C)

Assuming the fluid is water, the formula takes the more common form of;

$$\text{Load (btu/hr)} = \text{Flow(USgpm)} \times (\text{°F}_{\text{in}} - \text{°F}_{\text{out}}) \times 500 \quad (2)$$

Or

$$\text{Load (tons)} = \text{Flow(USgpm)} \times (\text{°F}_{\text{in}} - \text{°F}_{\text{out}})/24 \quad (3)$$

Using this equation and the above design conditions, the temperature change in the evaporator is found to be 10°F. The water temperature entering the evaporator is then 54°F.

Most air conditioning design conditions are based on 75°F and 50% RH in the occupied space. The dew point for air at this condition is 55.08°F. Most HVAC designs are based on cooling the air to this dewpoint to maintain the proper RH in the space. Using a 10°F approach at the cooling coil means the supply chilled water needs to be around 44°F or 45°F.

The designer is not tied to these design conditions. In fact, more energy efficient solutions can be found by modifying the design conditions as the project requires.

Changing the chilled water flow rate affects a specific chiller's performance. Too low a flow rate lowers the chiller efficiency and ultimately leads to laminar flow. The minimum flow rate is typically around 3 fps (feet per second). Too high a flow rate leads to vibration, noise and tube erosion. The maximum flow rate is typically around 12 fps. The chilled water flow rate should be maintained between these two limits.

The condenser water flows through the condenser of the chiller. The condenser is also a heat exchanger. In this case the heat absorbed from the building plus the work of compression leaves the refrigerant (condensing the refrigerant) and enters the condenser water (raising its temperature). The condenser has the same limitations to flow change as the evaporator.

## Piping

The piping is usually steel, copper or plastic. The chilled water piping is a closed loop. A closed loop is not open to atmosphere. Figure 2 shows a simple closed loop with the pump at the bottom of the loop. Notice the static pressure created by the change in elevation is equal on both sides of the pump. In a closed loop, the pump needs only to overcome the friction loss in the piping and components. The pump does not need to “lift” the water to the top of the loop.

**Figure 2, Closed Loop**

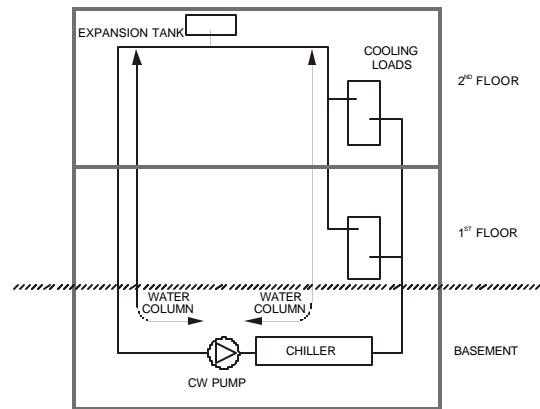

**Figure 3, Open Loop**

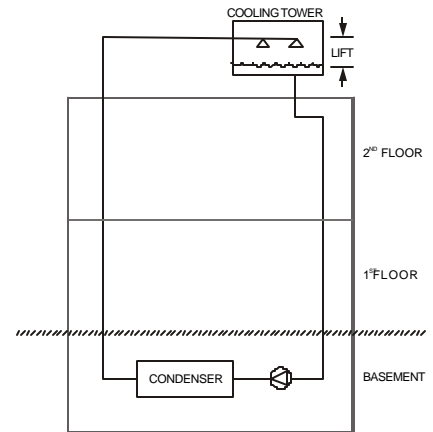

An expansion tank is required in the chilled water loop to allow for the thermal expansion of the water. Chilled water piping is insulated since the water and hence the piping is below the dewpoint temperature. Condensate would form on it and heat loss would occur.

The condenser water piping is an open loop. Figure 3 shows an open loop with the water open to the atmosphere. When the pump is not running, the level in the supply and return piping will be even at the level of the sump. When the pump operates, it needs to overcome the friction loss in the system and “lift” the water from the sump level to the top of the loop. Condenser water piping is typically not insulated since there will be negligible heat gain or loss and sweating will not occur. However, if the piping is exposed to cold ambient conditions it could need to be insulated and heat traced to avoid freezing.

### Chilled Water and Condenser Water Pumps

Typically centrifugal type pumps are used for both condenser water and chilled water systems. They can be either inline or base mounted. The pumps must be sized to maintain the system dynamic head and the required flow rate. The pump selection and location must take into account Net Positive Suction Head (NPSH). NPSH is usually a bigger issue on the condenser pumps. Normally, the pumps are located so they discharge into the chiller heat exchangers.

To provide redundancy, multiple pumps are used. Common approaches are (1) a complete full-sized stand-by pump, or (2) the design flow is met by two pumps with a third stand-by pump sized at half the load. When multiple pumps are used in parallel, check valves on the discharge of each pump are required to avoid “short circuiting”.

### Cooling Towers

Cooling towers are used in conjunction with water-cooled chillers. Air-cooled chillers do not require cooling towers. A cooling tower rejects the heat collected from the building plus the work of compression from the chiller. Since it is common (but not necessary) to use a temperature range of 10°F, the cooling tower flow rate will be 3.0 gpm/ton compared to the chilled water flow rate which is 2.4 gpm/ton. The extra condenser water flow rate is required to accommodate the heat from the work of compression.

Cooling towers differ from closed circuit coolers in that closed-circuit coolers reject heat sensibly while cooling towers reject heat latently. Consider ambient design conditions of 95°F DB and 78°F wb. If closed circuit coolers are used, the condenser water must be warmer than the ambient dry bulb (typically 10°F warmer or 105°F). This raises the condensing pressure in the chiller and requires more overall power for cooling. Closed circuit coolers are larger than cooling towers for the same capacity and can be difficult to locate on the roof.

Cooling towers expose the condenser water directly to the ambient air in a process that resembles a waterfall. Approximately 1% of the design condenser water flow is evaporated. The latent energy required to evaporate the water lowers the remaining water's sensible temperature. The process is based on the ambient wet bulb temperature (78°F wb in the example) rather than the dry bulb temperature. ARI standard conditions at full load are based on 85°F entering condenser water temperature and 3.0 US gpm per ton. Lower condenser water temperatures can be produced in many climates with low wet bulb temperatures.

## Loads

### *Figure 4, Air Handling Equipment*



Chilled water coils are used to transfer the heat from the building air to the chilled water. The coils can be located in air handling units, fan coils, induction units, etc. The air is cooled and dehumidified as it passes through the coils. The chilled water temperature rises during the process.

Process loads can reject heat in the chilled water in a variety of ways. A common process load is a cooling jacket in machinery such as injection molding equipment. Here the chilled water absorbs the sensible heat of the process.

## Controls

There are two parameters that need to be considered for the chilled water loop. These are temperature and flow. The loop supply temperature is controlled at the chiller. The unit controller on the chiller will monitor and maintain the supply chilled water temperature (within its capacity range). The accuracy to which the chiller can maintain the set point is based on the chiller type, controller quality (a DDC controller with a PID loop is the best), compressor cycle times, the volume of fluid in the system, etc. Systems with fast changing loads (especially process loads) and small fluid volumes (close coupled) require special consideration.

**Figure 5, Chiller Controller**

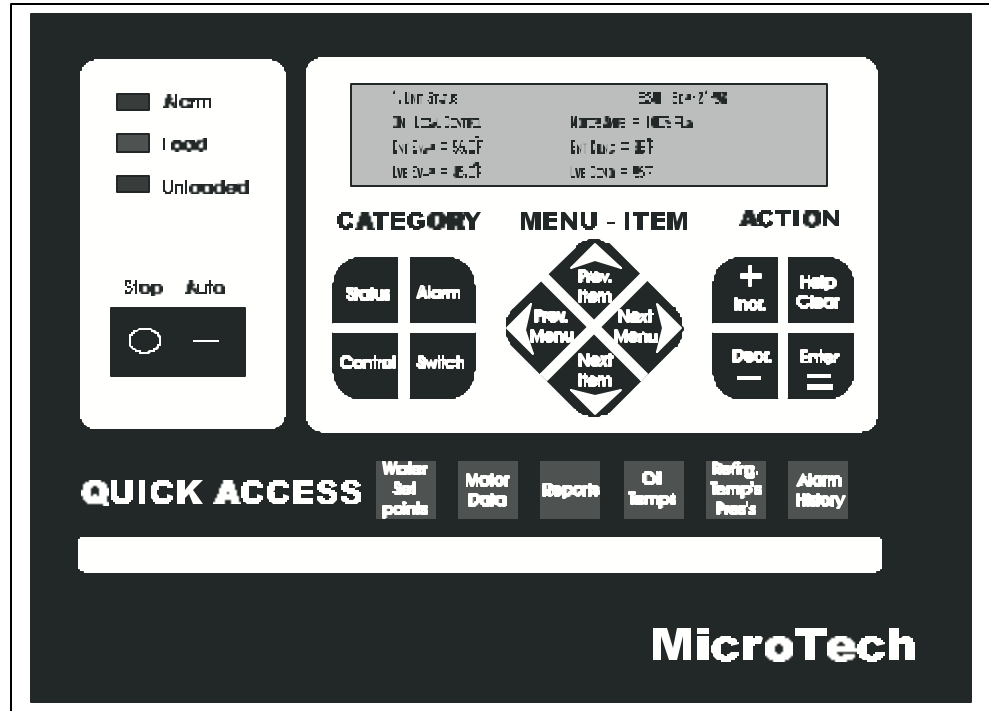

The system flow control occurs at the load. To maintain the correct space condition, three-way or two-way control valves are used. Three-way control valves direct chilled water either through or around the coil to maintain the desired condition. If all the loads on the loop use three-way valves then the chilled water flow is constant. The temperature range varies directly with the load. That is, if the design chilled water Delta-T is 10°F, then every 10% drop in system load represents 1°F drop in Delta-T.

**Figure 6, Three-way Valves**

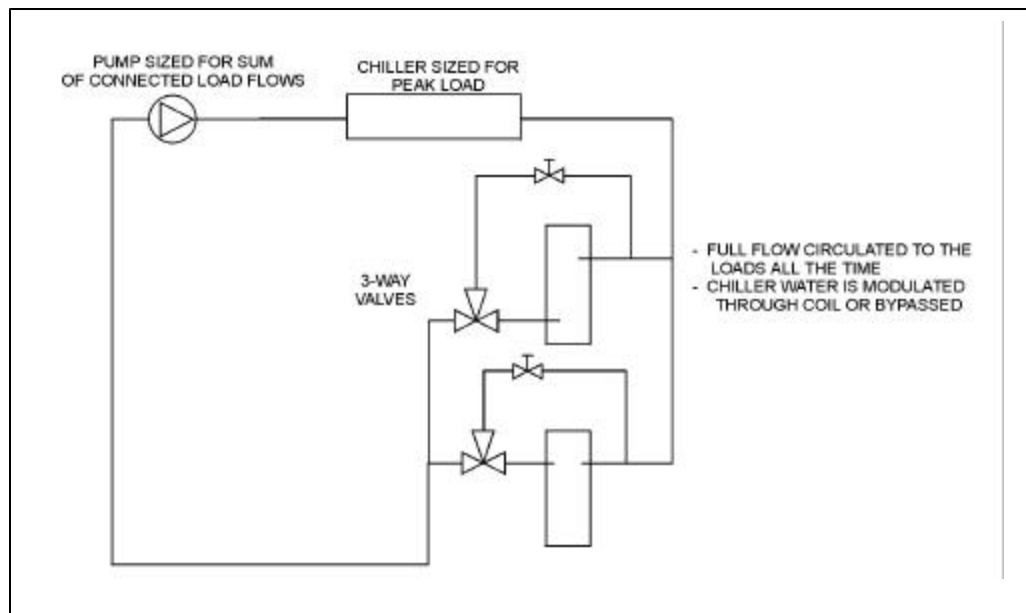

## Diversity

A system incorporating three-way control valves is easy to design and operate. However, the system pumps all the water all the time, which requires more pump horsepower. In most cases the chiller is sized for the building peak load. Due to diversity, not all the connected loads will “peak” at the same time as the building peak load. However, the pumps and piping system must be designed for full flow to all the control valves all the time. Since the chiller flow rate is the same as the flow rate through all the loads (they’re connected by the same piping system and pump) the diversity is applied to the chiller Delta-T.

For example, consider a building with an 80-ton peak load. However, summing all the connected loads adds up to 100 tons. In short, this building has a diversity of 80%. Using a delta of 10°F at each control valve, the total system flow rate is;

$$\text{Flow} = 24 \times 100 \text{ tons}/10^\circ\text{F} = 240 \text{ gpm}$$

However, an 80-ton chiller with 240 gpm will only have a Delta-T of 8°F. The lower chiller Delta-T is not a problem for the chiller operation, but it will lower the chiller efficiency. Care must be taken to select the chiller at the proper Delta-T.

**Figure 7, Two-way Valves**

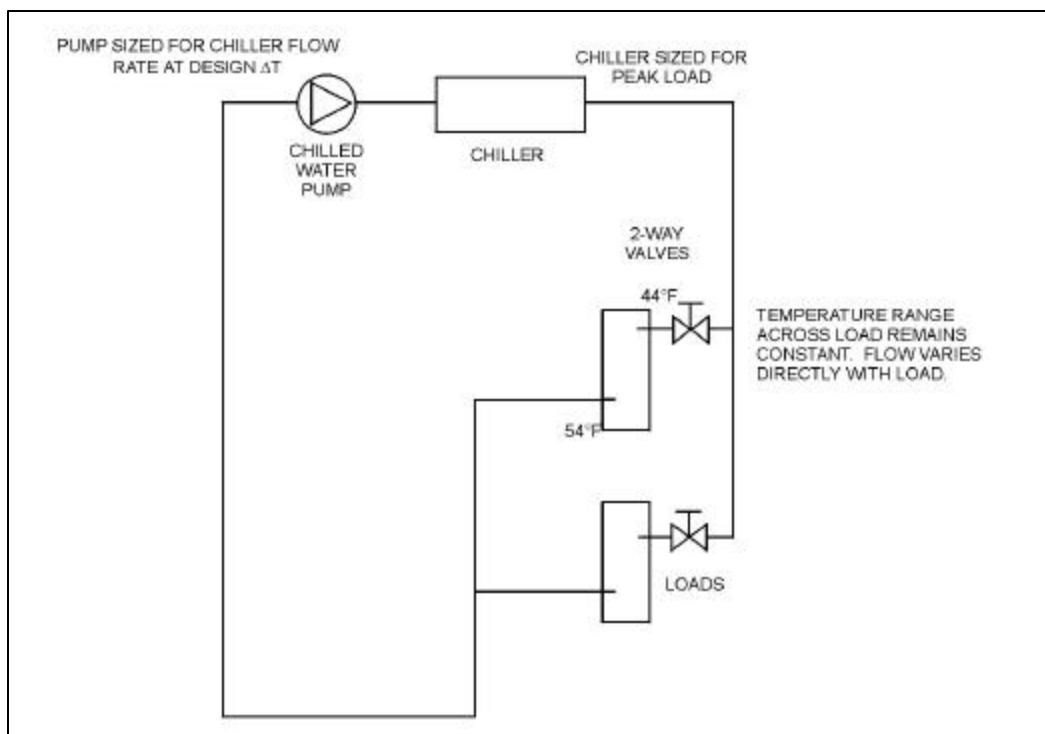

When two-way modulating control valves are used, the flow to the coil is restricted rather than bypassed. If all the valves in the system are two-way type, the flow will vary with the load. If the valves are properly selected, the temperature range remains constant and the flow *varies* directly with the load. In this case the *diversity* is applied to the *chilled water flow rate*.

Using the previous example, the peak load is 80 tons and the design flow is 2.4 x 80 tons or 192 gpm. The connected load is still 100 tons and requires 240 gpm *if* all the two-way

control valves are open at the same time. The 80% diversity assumes only 80% of the valves will be open at the peak load.

The advantage of two-way control valves is both the pump and the piping are sized for a smaller flow rate offering both first cost and operating savings. The difficulty is the chiller and control system must be designed for variable flow. The chiller has a minimum flow rate so the piping design has to allow for enough flow during all operating conditions to meet the chiller minimum flow rate. Using two-way valves at the loads is the main building block for a variable flow system.

## Parallel Chillers

To provide some redundancy in the HVAC design, most designers will require two or more chillers. Multiple chillers also offer the opportunity to improve on overall system part load performance and reduce energy consumption.

Figure 8 shows two chillers in parallel and three-way valves at the loads. The chilled water temperature difference varies directly with the load. The other system components are the same as the previous example. The difficulty with this parallel arrangement is the system part load performance.

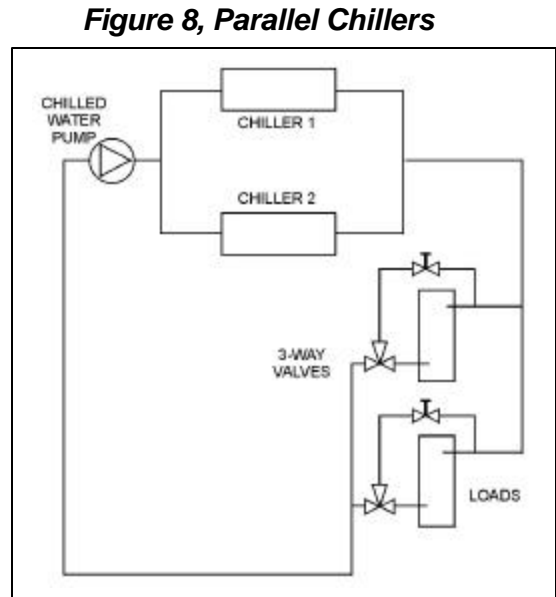

Consider the system operating at 50%. From a chiller performance aspect, turning off one chiller and operating the other at full capacity is desirable. However, this will not happen. At 50% capacity, the return water will be 49°F. The chiller that is turned off, will let the water pass through it unchanged. The operating chiller will only see a 50% load (49°F return water), and will cool the water down to the set point of 44°F. The two chilled water streams will then mix to 46.5°F supply temperature.

If the system is operated in this manner, the warmer chilled water will cause the control valves to open (increase flow) to meet the space requirements. The return water temperature will rise affecting the supply system supply water temperature. An iterative process will occur and the system can stabilize. The issue is whether the cooling coils can meet the local loads with the higher chilled water temperature. Depending on the actual design conditions, the building *sensible* load could be met but high chilled water temperature will make it difficult to meet the *latent* load. Since this scenario is likely to occur during shoulder weather, dehumidification can not be an issue. In areas where humidity is an issue, this arrangement will result in high humidity within the space.

One solution is to operate both chillers all the time. This works and is a simple solution, however, it is not energy efficient and causes unnecessary equipment wear.

Another possibility is to lower the operating chiller's set point to offset the mixed water temperature. This too works but has some difficulties. Lowering the chilled water set point

requires the chiller to work harder lowering its efficiency. In extreme conditions, it can cause chiller stability issues.

**Figure 9, Parallel Chillers with Isolating Valves**

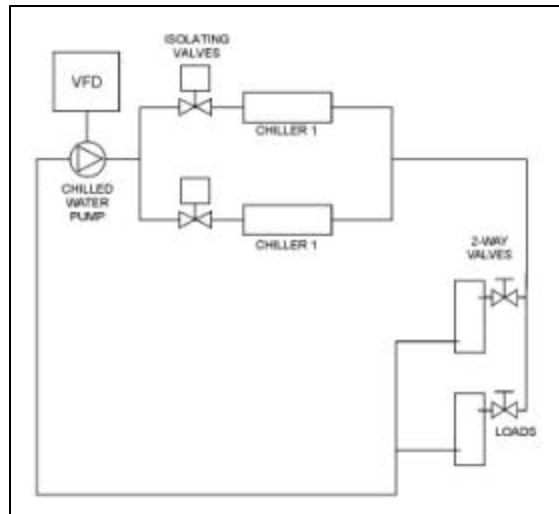

Figure 9 shows a modified version of parallel chillers. This concept incorporates isolating valves for each chiller. The chilled water pump includes a Variable Frequency Drive (VFD). The loads now have two-way valves.

In this design concept, as the system load decreases, the flow is reduced until one of the chillers can be shut down and its isolating valve is closed. Supply water temperature remains constant.

This design requires careful chiller selection to provide good flow characteristics over the required operating

range. More sophisticated controls are required to operate the system. See Variable Flow Design for further details.

## Series Chillers

**Figure 10, Series Chillers**

Figure 10 shows two chillers in series. This design concept resolves the mixed flow issues found in parallel chiller designs. It is simple to design and operate. However, it also has some challenges to overcome.

All the system flow goes through both chillers. If both chillers are the same and the condensers are piped in parallel, the lead chiller will accomplish about 45% of the system load and the lag chiller will accomplish about 55% of the system load.

This occurs because the lead chiller is supplying chiller water at the system set point (typically 44°F). The lag chiller is supplying chilled water at approximately 48.5°F to the lead chiller. The reduced lift for the lag chiller allows it to provide more cooling capacity.

A problem with series chillers is the high flow rate and the low Delta T through the chillers. The high flow rate can result in high water pressure drops. Since the chillers are in series, the pressure drops of the chillers must be added. If the typical 10°F system temperature

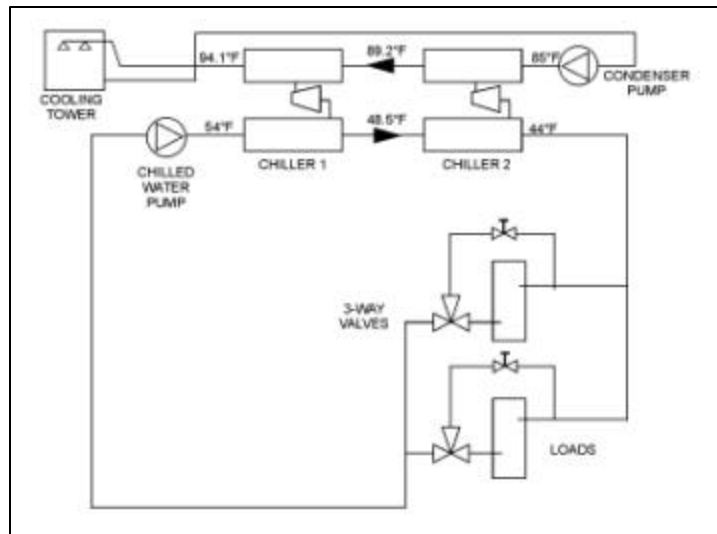

difference is maintained, then single pass evaporators should be considered. This will lower the pressure drop to an acceptable level.

There is an opportunity to optimize series chillers and improve overall system performance by connecting the condensers in series as well. Figure 10 shows the condensers connected in series with the condenser flow counter flow to the chilled water flow.

**Table 1, System Efficiency Comparison**

CHILLER VESSEL PIPING	CAP	EVAP EWT	EVAP LWT	EVAP FLOW	COND EWT	COND LWT	COND FLOW	MODEL	POWER	PERF.
	(tons)	(°F)	(°F)	(GPM)	(°F)	(°F)	(GPM)		(kW)	(kW/T)
PARALLEL CH-1	400	54	44	960	85	94.2	1200	WSC087	218.0	0.547
PARALLEL CH-2	400	54	44	960	85	94.2	1200	WSC087	218.0	0.547
<b>SYSTEM TOTAL</b>	<b>800</b>	<b>54</b>	<b>44</b>	<b>1920</b>	<b>85</b>	<b>94.2</b>	<b>2400</b>	-	<b>436.0</b>	<b>0.547</b>
SERIES OPT 1 CH-1	440	54	48.5	1920	85	95.1	1200	WSC087	205.6	0.520
SERIES OPT 1 CH-2	370	48.5	44	1920	85	93.5	1200	WSC087	228.6	0.556
<b>SYSTEM TOTAL</b>	<b>810</b>	<b>54</b>	<b>44</b>	<b>1920</b>	<b>85</b>	<b>94.2</b>	<b>2400</b>	-	<b>434.2</b>	<b>0.536</b>
SERIES OPT 2 CH-1	440	54	48.5	1920	89.1	94.1	2400	WSC087	232.7	0.529
SERIES OPT 2 CH-2	370	48.5	44	1920	85	89.2	2400	WSC087	193.6	0.523
<b>SYSTEM TOTAL</b>	<b>810</b>	<b>54</b>	<b>44</b>	<b>1920</b>	<b>85</b>	<b>94.1</b>	<b>2400</b>	-	<b>426.3</b>	<b>0.526</b>

Table 1 compares a parallel system with two versions of series systems for an 800 ton design load. The full load penalty for series option 1 compared to the parallel system is negligible. Series Option 2 shows chillers with series condenser flow. It provides the best overall system performance and either chiller can be the lead chiller. Series condensers and series evaporators are an excellent means to provide lower temperature, high Delta-T chilled water.

It should not be concluded that parallel systems have no value. In applications where most of the operating hours occur above 50% load, a parallel system typically does better. A series system does better when there lots of run hours below 50% such as an HVAC system without air side economizers.

### Series Chillers Controls

As before, the chiller controllers maintain the system supply water temperature and the load controls maintain the system flow rate. For series chillers, the controlling sensors for both chillers should be located downstream of the chillers and the chiller control panels digitally linked together. With the panels linked together, either chiller can be used to meet up to about 45% of the system load. Once both chillers are required, the amp draws can be balanced between the two chillers.

The MicroTech Controllers on McQuay chillers can communicate directly and can load balance based on amperage. Using the load balance feature means when both chillers operate, the power consumption is evenly distributed between the two chillers. The load balance feature offers about 3% savings conventional control.

### Primary/Secondary Systems

For large chillers or where more than 2 chillers are anticipated, primary/secondary (also called decoupled) piping systems are used. To reduce installation and operating costs, it is desirable to apply diversity to system flow. With diversity applied to flow, the pumps and piping will be smaller. To accomplish this, two-way control valves are used at the loads. At the same time it is necessary to provide constant flow through the chillers to maintain chiller stability. The solution is primary/secondary piping.

**Figure 11, Primary/Secondary Loop at Full Load**

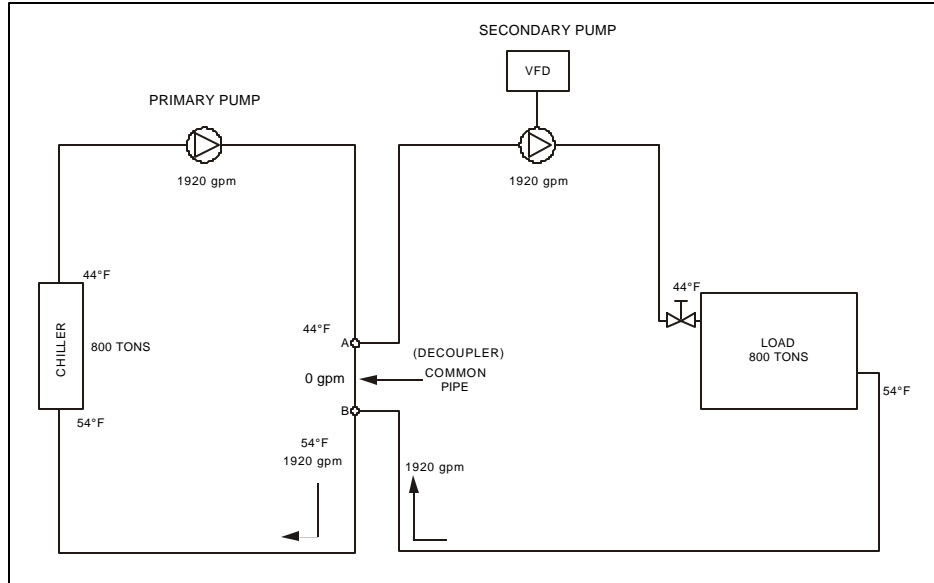

### Primary/Secondary Loop Basics

Figure 11 shows a basic primary/secondary loop operating at full load. In this example, the system design load is 800 tons, the flow rates and temperatures are at standard ARI conditions and the load has a two-way control valve. The loop with the chiller is called the primary loop. The loop with the load is the secondary loop. The common pipe is sometimes referred to as the decoupler.

At full load, the design flow of 1920 gpm passes through the chiller, the two pumps, the load, and back to the chiller. There is no flow through the common pipe. At first, it would appear that the flow is being pumped twice. Although this is true, the total head is *split* between the two pumps. The primary pump is only sized for the primary loop of which the chiller is main pressure drop. The secondary pump is sized for the pressure drop “outside the mechanical room”. The higher pressure drops and larger piping arrangements in the secondary loop justify the variable flow.

**Figure 12, Primary/Secondary Loop at 50% Load**

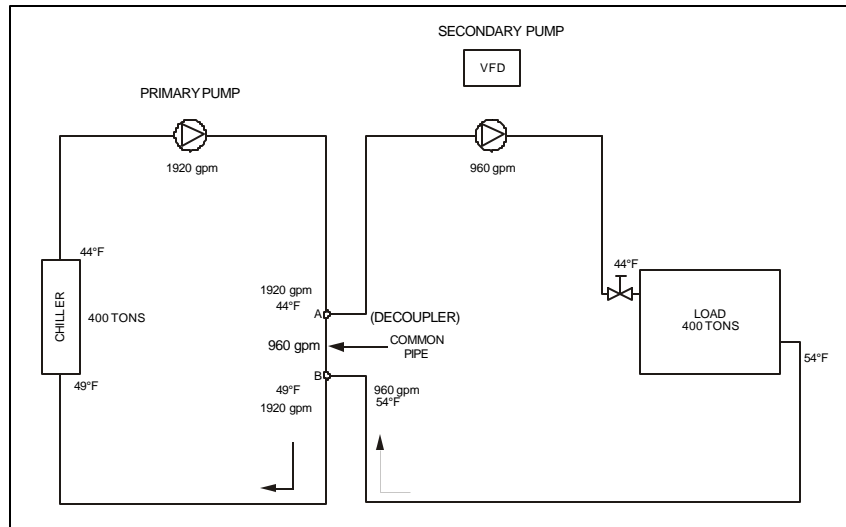
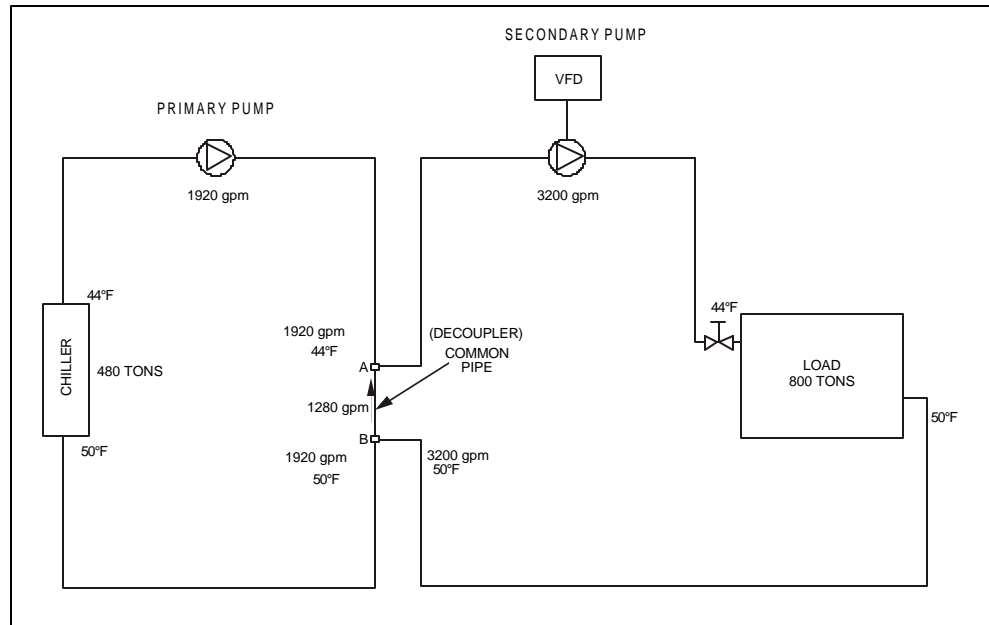

Figure 12 shows the same example operating at 50% capacity. The two-way control valve at the load has reduced the flow in the secondary loop to 960 gpm. The Delta-T across the load remains at 10°F. The primary pump is a constant flow pump sized for the chiller design flow. It remains constant at 1920 gpm. The additional flow not required in the secondary loop passes through the common pipe to the chiller return line. The 44°F fluid from the common pipe mixes with the 54°F return fluid to 49°F. The chiller maintains its design flow of 1920 gpm with 49°F RWT and 44°F LWT. The chiller sees a 50% load.

The example in Figure 12 demonstrates how diversity is applied to flow in the secondary loop. The variable flow in the secondary loop offers excellent pump operating savings and first cost saving in pipe sizing. The constant flow in the primary loop provides the chiller with stable operating conditions.

**Figure 13, Primary/Secondary Loop at Low Delta-T**



It is important to understand what happens if design temperature range is not maintained. This is known as a low Delta-T syndrome. Figure 13 shows the previous example with an 800 ton load but only a 6°F Delta-T. This could be caused by several factors including poor valve selection or dirty coils.

To meet the 800-ton load requirement, the control valve will respond by opening and allowing more flow through the load. The secondary pump will respond in turn by increasing the secondary loop flow to 3200 gpm to meet the load. The primary pump is only supplying 1920 gpm so 1280 gpm will flow “backward” through the common pipe to meet the 3200 gpm requirement. Two problems now occur. The supply fluid temperature in the secondary loop will rise when the primary fluid and the return fluid mix. The higher fluid temperature will cause the control valve to open further, making the problem worse. The second problem is the return water to the chiller is only 50°F so the chiller only sees a 480-ton load. This system will not function well under these conditions.

**Figure 14, Primary/Secondary Loop with Low Delta-T Reality**

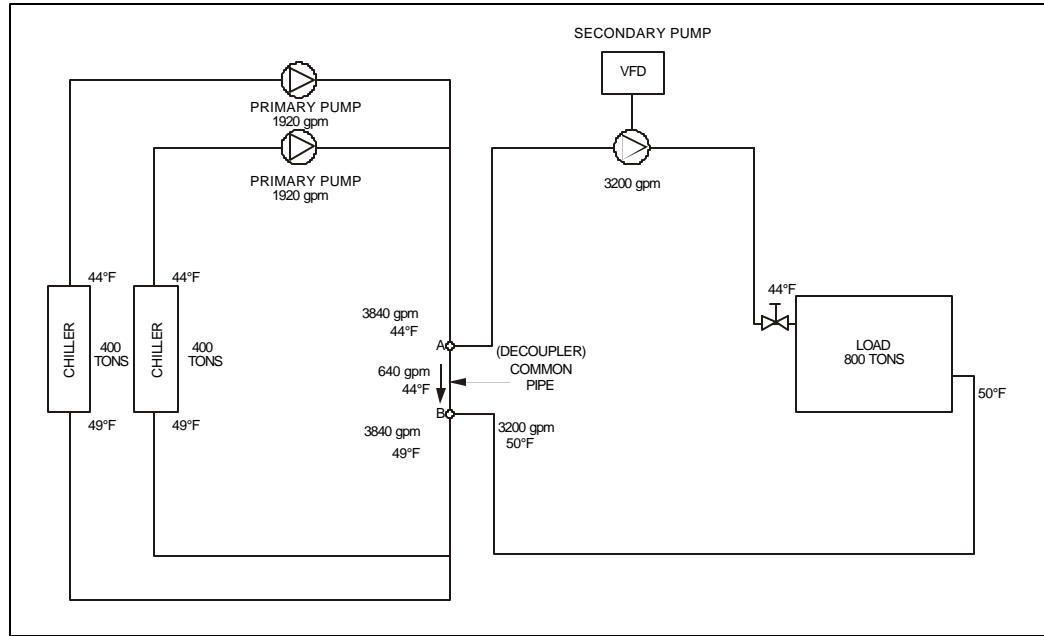

Obviously the above example can't occur. Figure 14 shows what does happen. A second chiller has to be started to balance the flow in the primary loop with the flow in the secondary loop.

Although running two chillers provides a working solution, many of the features of the primary/secondary approach are lost. The flow in the secondary is high, wasting pumping energy. Two primary pumps have to operate when only one should be doubling the primary pump horsepower. Finally, two chillers are operating (and their condenser water pumps) when only one should be.

### Primary Loop Details

The most common arrangement is to have dedicated pumps for each chiller. In addition, each chiller requires an isolating valve. It is also possible to have a main primary pump outfitted either with multiple speeds or a variable frequency drive. The issue with the latter is there is minimal to no redundancy available.

The chillers can have different capacities and be manufactured by different vendors. However, they must have the same supply water set point and the same chilled water Delta-T.

**Figure 15, Standard Primary Loop Layout**

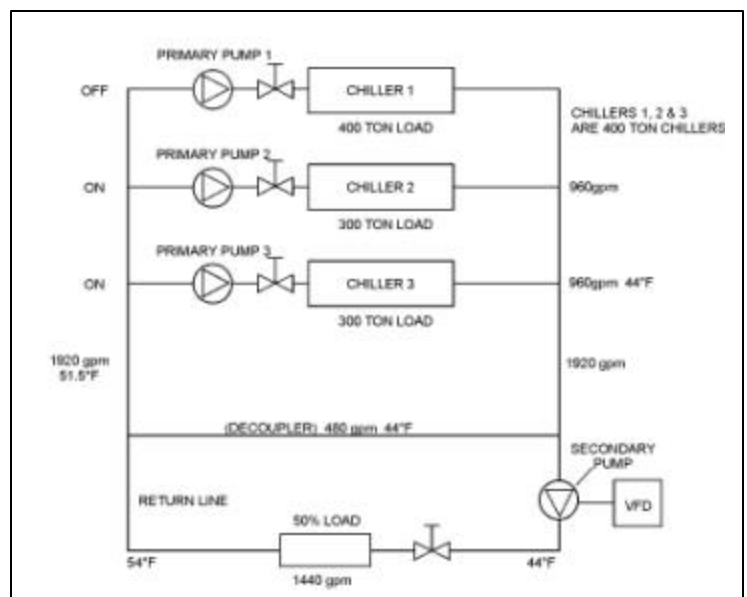

## Decoupler Location

The location of the decoupler line will change how the chillers are loaded. Figure 15 shows the typical layout. In this situation, each chiller sees the same return water temperature even at part load conditions.

Figure 16 shows the decoupler line in a different location. Locating the chillers between the secondary loop and the decoupler line causes the return water temperature to each chiller to vary. Chiller 2 in Figure 16 will see close to the secondary loop return water temperature. Chiller 1 will see a mixture of supply water and return water. The result is Chiller 2 is more heavily loaded than Chiller 1.

**Figure 16, Optional Primary Loop Layout**

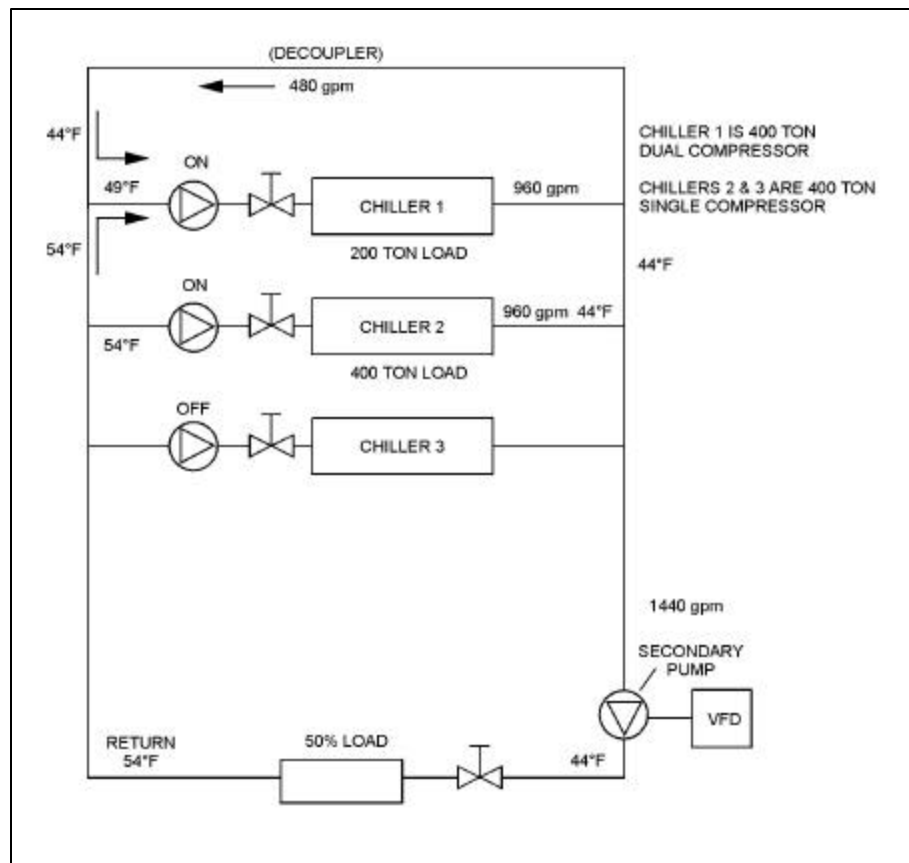

Relocating the decoupler can make sense if one or more of the chillers is a dual compressor model. The dual compressor chiller has very good part load performance. Single compressor chillers typically work best when fully loaded. By locating the dual compressor chiller close to the decoupler line and the single compressor chiller furthest away, the strengths of each chiller can be maximized. Table 2 shows the chiller plant performance for Figures 15 and 16. By base loading the single compressor chiller and taking advantage of the dual's part load performance, the power input can be cut by up to 10 percent.

**Table 2, Table 2 Chiller Plant Performance vs. Decoupler Location**

<b>Figure 15</b>	Cap. (tons)	RWT (°F)	SWT (°F)	<b>Power (kw)</b>
CH-1	300	51.5	44	124.6
CH-2	300	51.5	44	124.6
<b>Total</b>	<b>600</b>	51.5	44	<b>249.2</b>
<b>Figure 16</b>				
CH-1	200	49	44	73.2
CH-2	400	54	44	151.7
<b>Total</b>	<b>600</b>		44	<b>224.9</b>

## Secondary Loop Details

**Figure 17, Basic Secondary Loop**

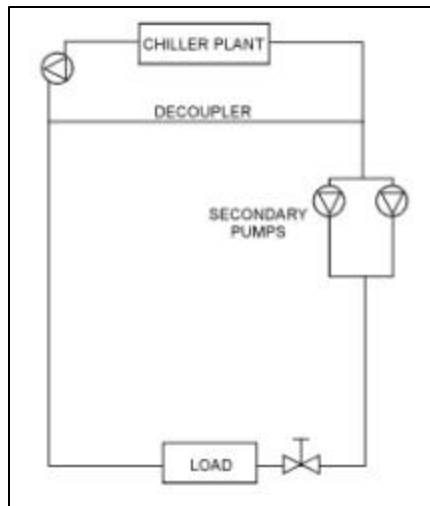

The secondary loop must be variable flow. Traditionally, multiple pumps were staged on to vary the flow. More recently, variable frequency drives are used. The primary/secondary arrangement allows the engineer a great deal of flexibility when designing the distribution piping. Figure 17 shows the basic design. Multiple secondary pumps are used to provide some redundancy.

**Figure 18, Multiple Secondary Loops**

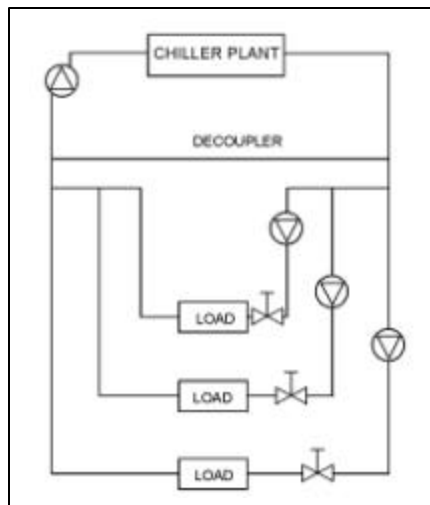

Figure 18 shows dedicated pumps for various loops. Multiple loops can serve areas with different operating schedules or widely different fluid pressure drops (such as a building on the far side of a campus). The individual loops can be scheduled off when not required.

Controlling the secondary pumps is a subject of some debate. Most systems today use some method of pressure differential across the secondary loop. The location for the pressure sensors is critical. Proper system operation requires that the load control valves be properly sized and the pressure sensors properly located. This is a discussion in itself and is beyond the scope of this manual.

## Reverse Return/Direct Return Piping

The examples used in this manual show reverse return piping. The secondary piping is designed such that any path through any load is the same length and therefore has approximately the same fluid pressure drop. Reverse return piping is inherently self-balancing. It also requires more piping and consequently is more expensive.

Direct return piping results in the load closest to the chiller plant to have the shortest path and therefore the lowest fluid pressure drop. Depending on the piping design, the difference in pressure drops between a load near the chiller plant and a load at the end of the piping run can be substantial. Balancing the system can be difficult. The advantage of direct return piping is the pipe savings.

The decision whether to use direct or reverse return piping should be based on system operability vs. first cost. Where direct return piping is used, flow-balancing valves should be carefully located so that the system can be balanced.

## Varying Chiller Sizes

One advantage of primary/secondary systems is varying the chiller sizes. As long as the supply water temperature and the design Delta-T are the same, the chillers can have different capacities.

Varying the chiller sizes allows chillers to be selected so the chiller plant is at maximum performance when the run-hours are highest. For example, consider a chiller plant where two chillers can be used. However, the bulk of the run-hours will be at 50% to 70% of design capacity. This will require the two chillers to operate between 50% and 70% of their design capacity. By varying the chiller sizes to one at 800 tons and one at 400 tons. The system load can be met with one chiller for the bulk of the operating time.

## System Expansion

**Figure 19, Expanding the System**

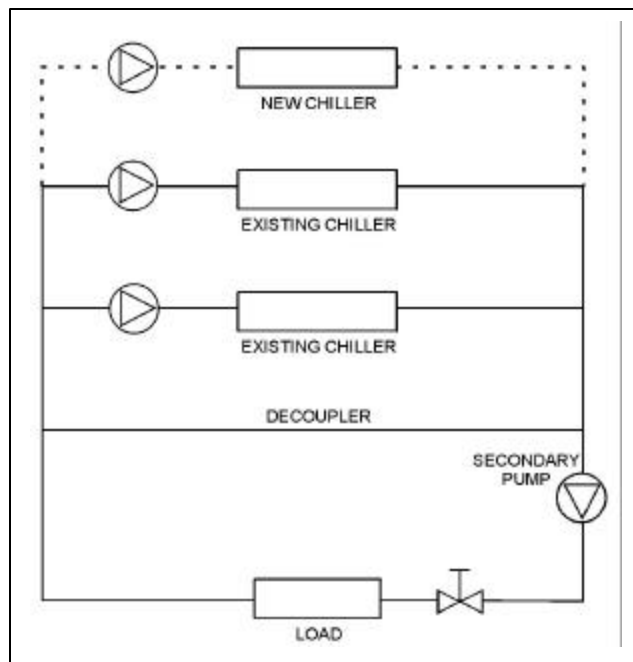

Primary/secondary piping allows easy expansion both in the chiller plant (primary loop) and the building (secondary loop). To expand the chiller plant capacity, another chiller can be added to the loop as shown in Figure 19. By strategically locating the decoupler and the new chiller (see Figure 16), it is possible to apply a greater load on the new chiller. This can be advantageous if the new chiller is more efficient than the rest of the plant.

If the building load is increased, a new loop can be added. The pump for the new loop can be sized to meet the new loop's pressure drop requirements.

# Water-Side Free Cooling

Some HVAC systems (fan coils) can require chilled water year round. Where the weather allows, water-side free cooling can avoid the need for mechanical cooling. Figure 20 shows a heat exchanger in parallel with the chiller. During free cooling the chiller is off and isolated by valves. The heat exchanger rejects heat into the condenser water loop. For this to happen the condenser loop must be colder than the chilled water loop (the reverse of chiller operation).

**Figure 20, Water-Side Free Cooling**

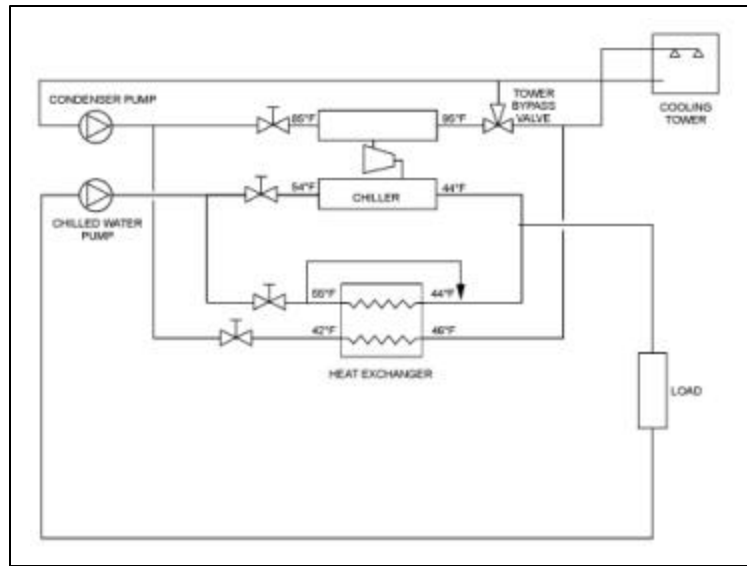

The actual winter chilled water supply temperature requires careful consideration. Since the cooling load is lower in the winter particularly, the latent load, the chilled water supply temperature can be higher than in the summer, 50°F to 55°F are common. The higher chilled water temperature allows the condenser water temperature to remain further away from the freezing point. With a

3°F to 5°F approach on the heat exchanger, the condenser supply water temperature can be around 45°F.

A key issue is the transition from free cooling to mechanical cooling. Once the building load cannot be met by free cooling, the chiller will need to be started. At that point, the condenser loop will be cooler than the chilled water loop, which is “backwards” from the chiller point of view. To allow the chiller to operate, a cooling tower bypass line and valve is required. The bypass valve will allow the chiller to raise the condenser loop temperature.

**Figure 21, Free Cooling in Series with Chillers**

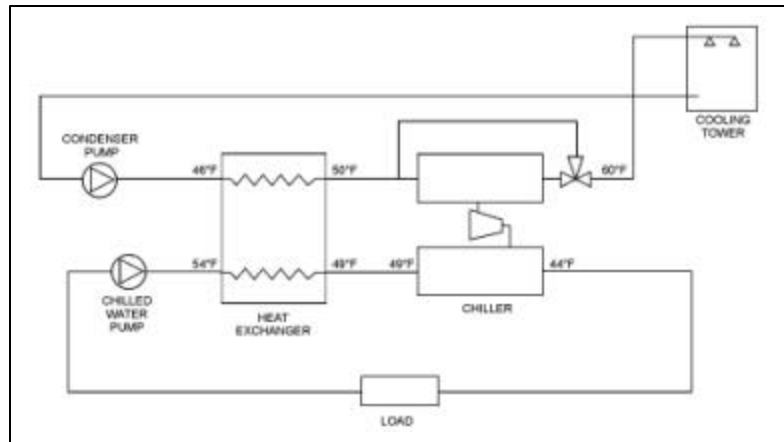

Figure 21 shows a different free cooling arrangement with the chiller in series with the heat exchanger. Since the heat exchanger operates with a higher chilled water temperature, the operating season is longer, offering more annual savings. The chiller trims the chilled water temperature and operates with significant condenser water relief. This arrangement works very well with process loads.

## Hybrid Plants

---

Mixing and matching different chiller types increases the designer's option in chiller plant design. To meet small winter chilled water loads, an air cooled chiller might be included in the chiller plant. The operator does not have to run the cooling towers in winter and the chiller is properly sized for the winter load. This is common in health care applications with water cooled equipment (MRIs, linear accelerators, etc.) The air-cooled chiller must be properly selected for winter operation.

To diversify the chiller plant on energy sources, an absorption chiller is often incorporated into the chiller plant design. The absorption chiller can operate on either plant steam or directly on natural gas. Either allows the operator to shave demand peaks for the electrical load. The absorption chiller can be in series or parallel (primary/secondary) with the electric chiller.

In a series application, the absorption chiller can be upstream of the electric chiller. The warmer return chilled water improves the efficiency of the absorption chiller by as much as 30%. This arrangement automatically base loads the electric chiller. Until the return water reaches 49°F, the absorption chiller won't operate. Once the building load climbs above 50%, the electrical demand is avoided, by using the absorption chiller. In shoulder weather, either chiller can be operated. (reset the absorption chiller set point to 44°F).

The condenser water needs of the absorption chiller are different from the electric chiller. Whereas electric chiller typically operates with 3 gpm/ton on the condenser side, an absorption chiller operates with 4.5 gpm/ton. Condenser water temperature stability and reset are also more critical with an absorption chiller. Care must be taken to properly integrate an absorption chiller into the chiller plant design.

# Variable Flow Design

Modern DDC controllers on chillers allow the possibility of variable flow design. Traditional thinking has been that the chiller should see constant flow and then the load will vary directly with the return fluid temperature. Allowing variable flow means the cooling load can vary either with the return fluid temperature or a change in the chilled water flow. It requires modern controllers to deal with two variables and provide stable chiller operation.

Variable flow allows the designer the option to use two-way control valves at the loads and apply diversity to flow while at the same time avoiding the complication of primary/secondary systems. This is particularly advantageous with small single chiller installations or where a dual compressor chiller is being considered instead of two single compressor chillers.

The range of flow rates in the chiller is limited at the low end by laminar flow in the tubes (3 fps tube velocity) and at the high end by tube erosion and vibration (10 fps tube velocity). Chiller selection software typically tries to pick a tube velocity of around 6 fps. When a chiller is intended for variable flow, the tube velocity should be picked closer to 10 fps. The chiller will only see high tube velocities at full load, which seldom occurs.

**Figure 22, Variable Flow**

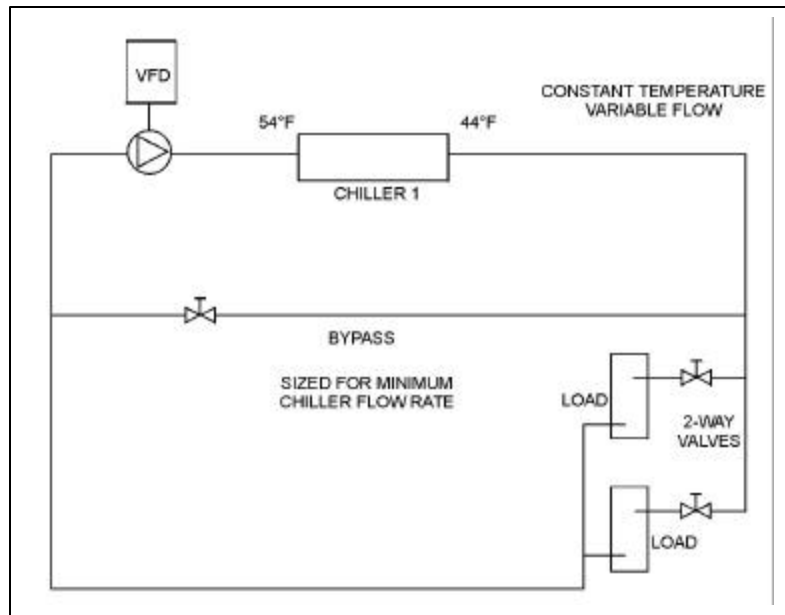

Selecting the chiller with tube velocities near 10 fps allows the system flow to be turned down to 30% of design flow. The designer should work with the actual minimum and maximum flow rates for the chiller selected on the project. The chiller manufacturer can provide this information.

If all the control valves are two-way, a bypass will be required and sized for the chiller's minimum flow rate (approximately 30% of design flow). Alternatively, some three-way valves can be used to provide minimum flow rate is maintained. However, the three-way valves will "consume" their design flow whether the fluid goes through the load or around it. This will reduce the overall pump savings potential. From an energy point of view, the pump

motor savings below 30% are minimal due to VFD losses and reduced motor efficiency. Operating at frequencies below 20 hz (33%) also puts unnecessary wear on the motors.

**Figure 23, Variable Flow with Parallel Chillers**

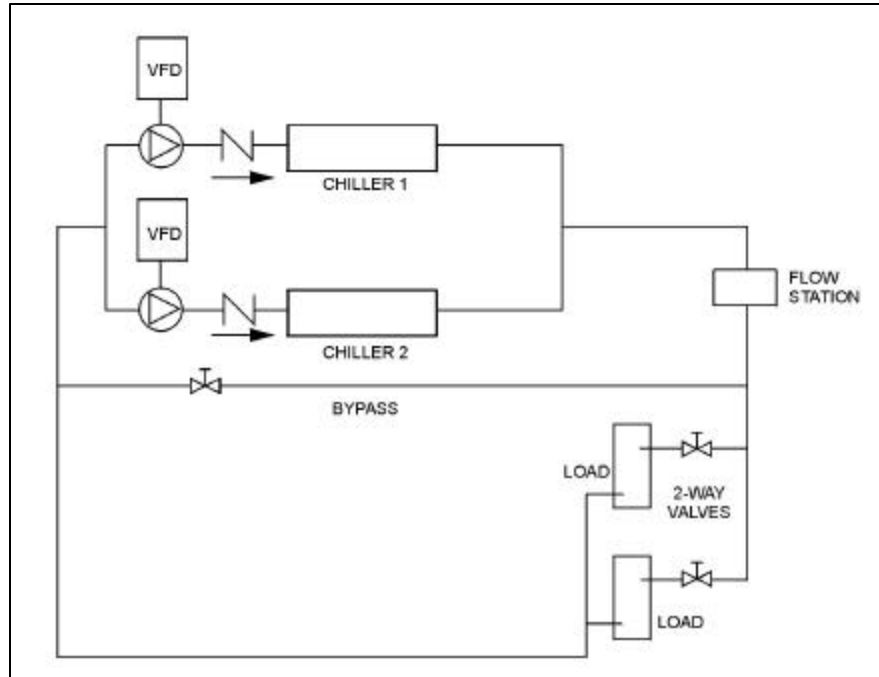

Variable flow can also be applied to chillers in parallel. Figure 23 shows two chillers in parallel with VFDs on the primary pumps. Variable flow allows the option of operating only one chiller when the system load is within the range of one chiller. The second chiller can be shut down and all the flow directed through the remaining chiller. Variable flow resolves most of the issues of parallel chiller design.

The bypass should be sized for the highest minimum flow rate of the chillers being used.

The critical issue for variable flow with parallel chillers is controlling the cycling of the chillers. This is best accomplished by measuring system flow. When the system load and flow rate can be met by a single chiller, the other chiller can be shut down. With one pump/chiller combination off line, the other pump will increase speed/flow until the required chilled water loop pressure differential is obtained. If the single chiller minimum flow cannot be met (the two valves are all nearly closed) the bypass line control valve can be opened to provide minimum chiller flow. Chiller/pump cycling should be controlled with anti-cycle time delays.

Even with modern chiller controllers, care should be taken that the system flow changes are slow. Slow flow changes will allow the chiller controller time to respond and provide stable system operation. Although each project is different, a good rule of thumb is to limit the rate of change to 10% of design flow per minute.





